

**NC**

## SPECIFICATIONS

Maximum operating pressure	5075 PSI (350 bar)
Temperature range	-4°F to 176°F
Poppet seat	Metal to metal
Material	Steel with trivalent (CR3) plated finish for corrosion protection
Size	Up to 2 inch
Options	7 PSI or 65 PSI cracking pressure Call for other settings

## DIMENSIONS

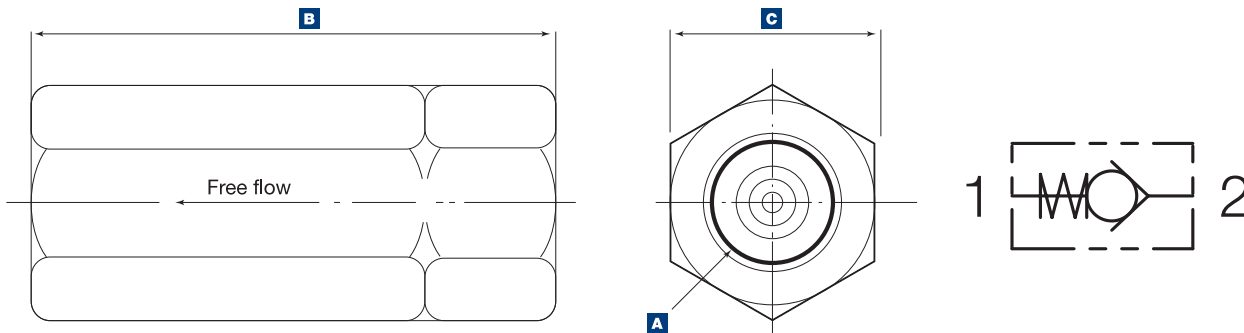

Model	A thread	B	C	Rated Flow	Weight	Model	A thread	B	C	Rated Flow	Weight
NC-250-S-*-NN	1/4" NPT	2.28"	0.75"	4 GPM	0.22 lb	NC-1000-S-*-N	1" NPT	4.33"	1.6"	39.6 GPM	1.7 lb
NC-250-S-*-SAE	7/16"-20 UNF	2.17"	0.75"	4 GPM	0.20 lb	NC-1000-S-*-SAE	1-5/16"-12 UNF	4.33"	1.6"	39.6 GPM	1.6 lb
NC-375-S-*-N	3/8" NPT	2.72"	0.95"	7.9 GPM	0.40 lb	NC-1250-S-*-N	1-1/4" NPT	4.72"	2.2"	52.8 GPM	3.3 lb
NC-375-S-*-SAE	9/16"-18 UNF	2.28"	0.75"	7.9 GPM	0.24 lb	NC-1250-S-*-SAE	1-5/8"-12 UNF	4.72"	2.2"	52.8 GPM	3.4 lb
NC-500-S-*-N	1/2" NPT	2.95"	1.0"	13.2 GPM	0.50 lb	NC-1500-S-*-N	1-1/2" NPT	5.43"	2.4"	79.2 GPM	5.7 lb
NC-500-S-*-SAE	3/4"-16 UNF	2.71"	0.95"	13.2 GPM	0.40 lb	NC-1500-S-*-SAE	1-7/8"-12 UNF	5.43"	2.4"	79.2 GPM	5.5 lb
NC-750-S-*-N	3/4" NPT	3.48"	1.38"	23.8 GPM	1.0 lb	NC-2000-S-*-N	2" NPT	5.43"	3.0"	113.5 GPM	6.6 lb
NC-750-S-*-SAE	11/16"-12 UNF	3.48"	1.38"	23.8 GPM	1.0 lb	NC-2000-S-*-SAE	2-1/2"-12 UNF	5.43"	3.0"	113.5 GPM	6.4 lb

## ORDERING INFORMATION

<p><b>NC-</b> Check valve series</p>	<p><b>500</b> Size 250 - 1/4" 375 - 3/8" 500 - 1/2" 750 - 3/4"</p>	<p><b>S-</b> Material Steel</p>	<p><b>65-</b> Cracking pressure 7 - 7.25 PSI 65 - 65.25 PSI</p>	<p><b>SAE</b> Threads N - NPT SAE - SAE</p>
--	--	---	---	---

## PERFORMANCE CURVES

